

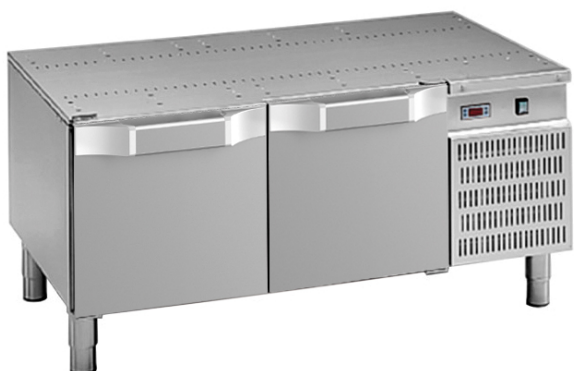

DOMINA PRO 700 - SOUBASSEMENT

**BR772P**



## SOUBASSEMENT REFRIGERÉE VENTILÉE

### SPÉCIFICATIONS TECHNIQUES:

Dimensions exterieure - LxPxH (cm)	120x70x60
------------------------------------	-----------

### SPÉCIFICATIONS SUPPLÉMENTAIRES:

Poids (kg)	80
Volume (m3)	0,9

La gamme DOMINA PRO 700 de soubassement baie libre se compose de modèles de différentes tailles. La gamme DOMINA PRO 700 de bases réfrigérées ventilées se compose de modèles à 2/3 tiroirs ou 2/3 portes. Préparé pour supporter les éléments de cuisson.

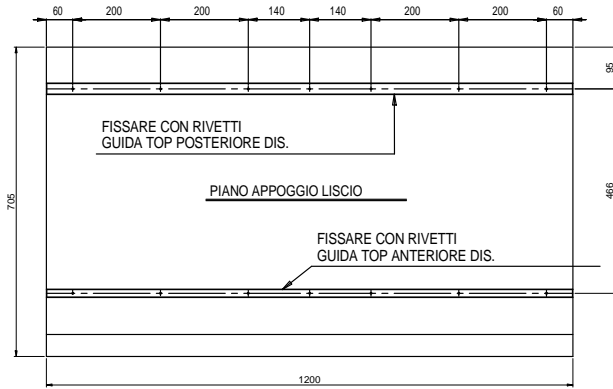
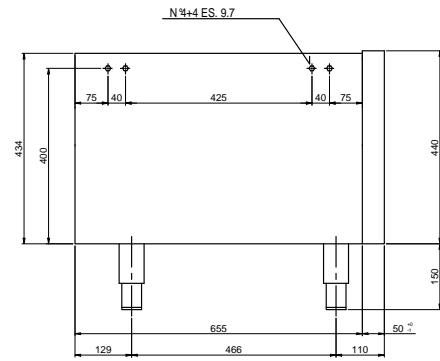
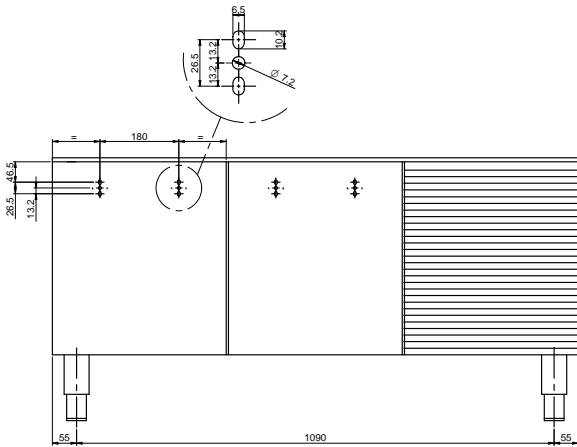

- BASE REFRIGERATA DOMINA PRO 700 / Refrigerated base Domina PRO 700
- N°2 VANO GASTRONORM 1/1 / n.2 gastronorm 1/1 cupboards
- RIVESTIMENTO AISI 304 SCOTCH BRITE / AISI 304 s/s scotch brite
- N°4 INSERTI ES.M6 SU LATO DX. E SX. / n.4 inserts M.6 on right and left sides
- N°1 GUIDA TOP ANTERIORE FISSATA SUL COPERCHIO / n.1 front top guide fixed on the lid
- N°1 GUIDA TOP POSTERIORE FISSATA SUL COPERCHIO / n.1 back top guide fixed on the lid

BASE REFRIGERATA 2P. L=1200 FTF0002109